

Real world capacitors and inductors include the ideal model along with resistors and, perhaps, inductors and capacitors. This document addresses the effect on the voltage across the primary resistor in both parallel and series RLC circuits due to using real world models. There are a number of such models but we will use the ones that only introduce additional resistances in the circuits to keep the differential equations to second order.

The capacitor and inductor models we are using, shown below, were given in Lessons in Electric Circuits V. II – AC on pages 75 and 97, available from www.ibiblio.org/obp/electricCircuits.

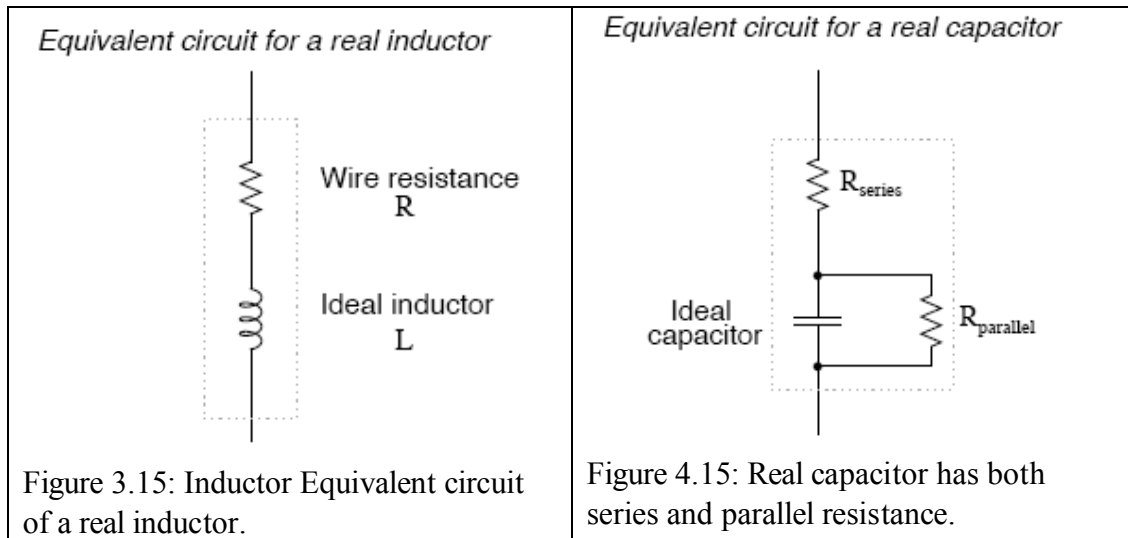

As you might suspect, inclusion of the additional resistors results in coupled differential equations. Thanks to Laplace Transforms, we can significantly simplify the problem by looking in *s* space.

Consider the voltage drops across the various elements. We assume the initial conditions are zero. There are methods in textbooks for handling non-zero initial conditions that include creating artificial circuit elements so that the initial conditions can still be taken as zero. Hence taking the derivative in time just leads to multiplication by *s* in the frequency domain.

Time (t)	Frequency (s)	Equation #
$V_R(t) = RI_R(t)$	$V_R(s) = RI_R(s)$	(1)
$V_C(t) = \frac{1}{C}Q_C(t)$ Take the derivative. $\frac{d}{dt}V_C(t) = \frac{1}{C}I_C(t)$	$sV_C(s) = \frac{1}{C}I_C(s)$ Divide by <i>s</i> . $V_C(s) = \frac{1}{sC}I_C(s)$	(2)
$V_L(t) = L\frac{d}{dt}I_C(t)$	$V_L(s) = sLI_C(s)$	(3)

In the table below are the circuit diagrams for series and parallel RLC circuits. The diagrams show the circuits, both with ideal and the models we are using for capacitors and inductors, in both the time domain and the frequency domain.

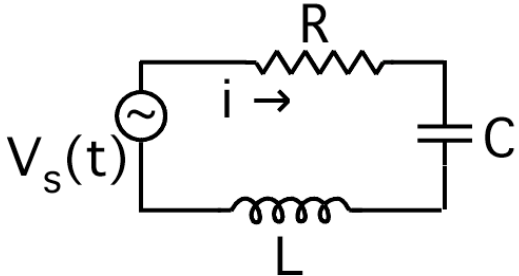
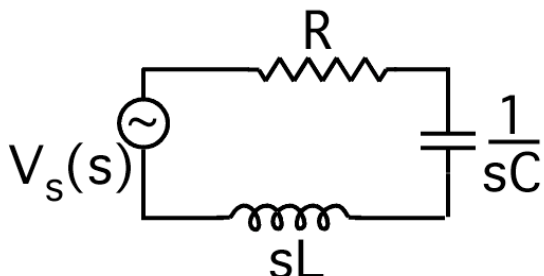
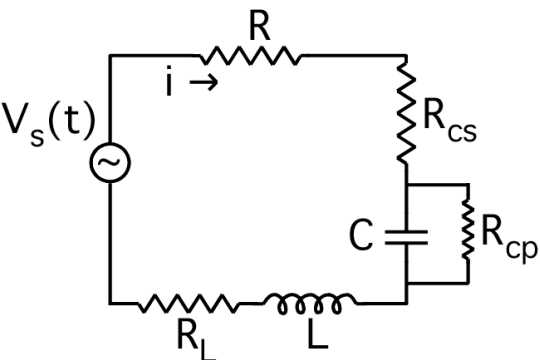
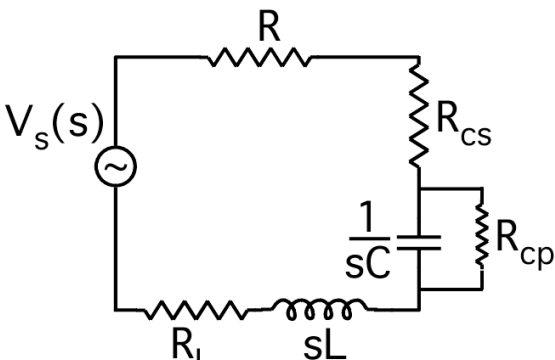
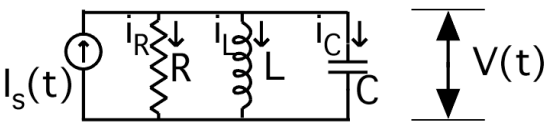
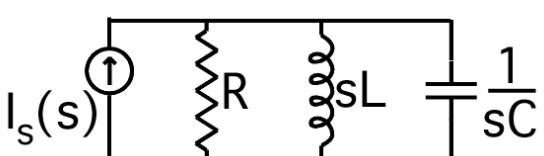
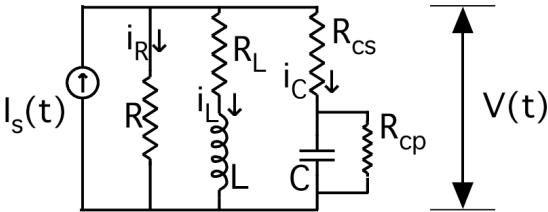
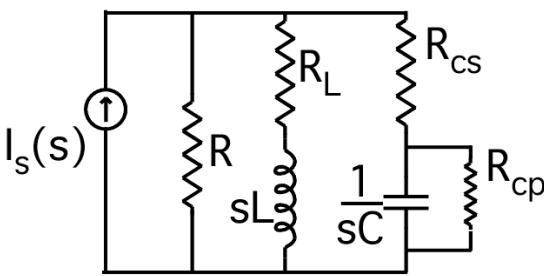
Time	Frequency (s)
	
	
	
	

As indicated above, time domain analysis of these circuits results in coupled differential equations. We know that the use of Laplace Transforms takes differential equations and turns them into algebraic equations. The analysis of the frequency domain circuits is algebra intensive so I used a symbolic algebra program, *LiveMathMaker* (nee *Theorist*), to do the work for me. The results are shown in the diagram below.

Real world RLC circuits from Patricia

Parallel

$$\frac{Vofs}{R} + \frac{Vofs}{R_L + Ls} + \frac{Vofs}{R_{cs} + \frac{R_{cp}}{1 + sCR_{cp}}} = Iofs$$

Messy equations

Define conglomerate parameters

$$A = (R_{cp} + R_{cs} + R)R_L + RR_{cp} + RR_{cs}$$

$$B = CL(R_{cs} + R)R_{cp}$$

$$D = CRR_L R_{cp} + LR_{cp} + CR_L R_{cp} R_{cs} + CRR_{cp} R_{cs} + LR_{cs} + LR$$

$$E = R(R_{cp} + R_{cs})R_L$$

$$F = R(LR_{cp} + CR_L R_{cp} R_{cs} + LR_{cs})$$

$$G = CLR R_{cp} R_{cs}$$

Resulting differential equation

$$(A + Bs^2 + Ds)Vofs = (E + Gs^2 + Fs)Iofs \quad \text{Substitute}$$

Series

$$Vofs = IofsR + IofsLs + IofsR_L + Iofs\frac{R_{cp}}{1 + sCR_{cp}} + IofsR_{cs}$$

Messy equations

Define conglomerate parameters

$$F = CR_{cp}$$

$$E = 1$$

$$D = CRR_L R_{cp} + CRR_{cp} + CR_{cp} R_{cs} + L$$

$$B = CLR_{cp}$$

$$A = R_L + R_{cp} + R_{cs} + R$$

Resulting differential equation

$$(E + Fs)Vofs = (A + Bs^2 + Ds)Iofs \quad \text{Substitute}$$

The words *messy equations* in the above are the titles of groups of hidden algebraic manipulations in *LiveMathMaker*, viewable upon request.

Consider the results for the parallel circuit. The final equation is

$$(Bs^2 + Ds + A)V(s) = (Gs^2 + Fs + E)I_s(s) \quad (4)$$

Recall that the current source is represented by

$$I_s(t) = I_0 \sin(\omega t) \quad (5)$$

Its Laplace Transform is

$$I_s(s) = I_0 \left(\frac{\omega}{s^2 + \omega^2} \right) \quad (6)$$

We can then solve equation (4) for the Laplace Transform of the voltage

$$V(s) = I_0 \frac{(Gs^2 + Fs + E)}{(Bs^2 + Ds + A)} \left(\frac{\omega}{s^2 + \omega^2} \right) \quad (7)$$

Use the TI-89 *Expand()* command or use a partial fraction expansion to rewrite equation (7) as a collection of identifiable inverse transforms, then use the Laplace Transform table to find the voltage across all the branches as a function of time. The equation for the series RLC configuration follows the same analysis with the result being the current through the elements in series as a function of the applied voltage, $V_s(t) = V_0 \sin(\omega t)$.

We can also recover the differential equation for the system in the time domain. Start with equation (4). Recall that multiplication by s in the frequency domain is equivalent to a derivative in the time domain. Therefore equation (4) looks like the following in the time domain.

$$B \frac{d^2}{dt^2} V(t) + D \frac{d}{dt} V(t) + AV(t) = G \frac{d^2}{dt^2} I_s(t) + F \frac{d}{dt} I_s(t) + EI_s(t) \quad (8)$$

Since we know the time dependence of the current source, $I_s(t) = I_0 \sin(\omega t)$, equation (8) becomes

$$B \frac{d^2}{dt^2} V(t) + D \frac{d}{dt} V(t) + AV(t) = I_0 \left\{ -G\omega^2 \sin(\omega t) + F\omega \cos(\omega t) + E \sin(\omega t) \right\} \quad (9)$$

The right hand side of equation (9) is just a sine or cosine wave with a phase shift.

$$B \frac{d^2}{dt^2} V(t) + D \frac{d}{dt} V(t) + AV(t) = I_0 \alpha \cos(\omega t - \delta) \quad (10)$$

where α is a multiplier that is a function of E , F , G , and ω .

We find the values of the phase shift, δ , and amplitude factor, α , by using a trig identity.

Given

$$\alpha \cos(\omega t - \delta) = (E - G\omega^2) \sin(\omega t) + F\omega \cos(\omega t) \quad (11)$$

we use the trig identity

$$\alpha \cos(\omega t - \delta) = \alpha \{ \sin(\delta) \sin(\omega t) + \cos(\delta) \cos(\omega t) \} \quad (12)$$

to arrive at,

$$\alpha \sin(\delta) = E - G\omega^2 \quad (13)$$

and

$$\alpha \cos(\delta) = F\omega \quad (14)$$

Dividing equations (13) and (14) gives us

$$\tan(\delta) = \frac{E - G\omega^2}{F\omega} \quad (15)$$

The appropriate quadrant for δ is determined by looking at the signs of equations (13) and (14).

Squaring (13) and (14), adding the results, then taking the square root of the result gives

$$\alpha = \sqrt{(E - G\omega^2)^2 + F^2\omega^2} \quad (16)$$

We now rewrite equation (10) so it looks like (almost) an RLC parallel circuit with effective values of R , L and C .

$$\frac{\omega B}{\alpha} \frac{d^2}{dt^2} V(t) + \frac{\omega D}{\alpha} \frac{d}{dt} V(t) + \frac{\omega A}{\alpha} V(t) = I_0 \omega \cos(\omega t - \delta) \quad (17)$$

Define

$$C_{\text{eff}} \equiv \frac{\omega B}{\alpha}, \quad R_{\text{eff}} \equiv \frac{\alpha}{\omega D}, \quad L_{\text{eff}} \equiv \frac{\alpha}{\omega A}, \quad \text{and} \quad \delta \equiv \omega t_0 \quad (18)$$

Then equation (17) becomes

$$C_{\text{eff}} \frac{d^2}{dt^2} V(t) + \frac{1}{R_{\text{eff}}} \frac{d}{dt} V(t) + \frac{1}{L_{\text{eff}}} V(t) = \frac{d}{dt} I_0 \sin\{\omega(t - t_0)\} \quad (19)$$

which, except for the shift in time, is the same as the equation for a simple parallel RLC circuit.

$$C \frac{d^2 v}{dt^2} + \frac{1}{R} \frac{d}{dt} v + \frac{1}{L} v = \frac{di_s}{dt} \quad (20)$$

with $i_s(t) = I_0 \sin(\omega t)$.

A similar analysis can be performed for the series RLC circuit case.

Since we assumed zero initial conditions to arrive at equation (13) via Laplace Transform methods, the effective circuit described by equation (13) will result in non-zero initial conditions due to the time shift in the current source.

The impact of using our models of real world capacitors and inductors leads not only to effective inductors and capacitors, as provided by the left hand side of equation (10), but it also modifies the current source in amplitude and phase, as provided by the right hand side of equation (10).

For the parallel RLC circuit case, the voltage across the primary resistor is found by solving equation (7), then back transforming or by solving equation (10) using conventional time dependent techniques. For the series RLC circuit case, we find the current through the resistor then multiply by the resistance, R , to find the voltage across the resistor.

I am deeply indebted to Patricia Mellodge for providing the above analysis. She turned my intractable problem into one that we could analyze and understand.